

MULTITOOL

MODEL	MULTITOOL
WEIGHT (Kg)	61
OIL PRESSURE (bar)	200
OIL FLOW (l/min)	20-50
A DIMENSION (mm)	240
B DIMENSION (mm)	908
C DIMENSION (mm)	612

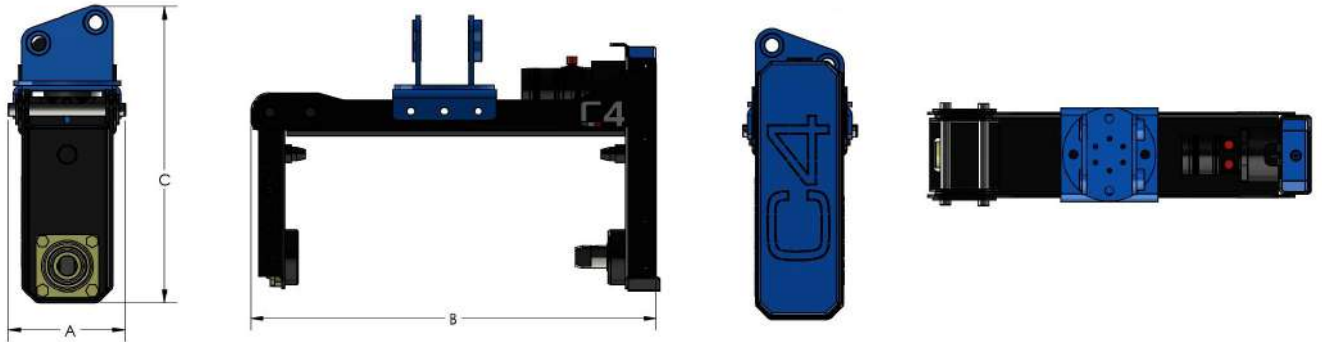

A NEW C4 BRANDED PRODUCT FOR MINI EXCAVATORS.
It can be applied on excavators from 1.8 to 3 tons.

The hydraulic system has been suitably designed and sized to ensure downstream the power required by the tool group and upstream to adapt to the incoming oil flow rates by the excavator. The heart of the equipment is the tool support frame, which is the interface that allows the connection of the tools to the tool holder frame while keeping only one main machine body. These features make our Multitool a product highly versatile and useful for many uses.

	<p>Quick change tool system through pins.</p>		<p>Transmission with reduced chain.</p>		<p>Standard with manually adjustable attachment on 4 positions.</p>
--	---	--	---	--	---

ACCESSORIES

CATENARY



Tool for creating excavations. Standard with screw extraction of the material.

WEIGHT (Kg)	65
NUMBER OF TOOLS	26
CUTTING DEPTH (mm)	500
DIGGING WIDTH (mm)	60

AERATOR



Tool for the care and maintenance of the turf.

WEIGHT (Kg)	50
WIDTH (mm)	700
DIAMETER (mm)	335
NUMBER OF POINTS	40