

T SERIES

T15/TV15

T20/TV20

T50/TV50

MODEL (multifunctional)	T15	T20	T50
MODEL (1-pin attachment without locks)	TV15	TV20	TV50
EXCAVATOR (ton)	1.5-3	3-5	5-10.5
A DIMENSION (mm)	475	600	720
B DIMENSION (mm)	250	300	300
WORKING TORQUE (N/m)	1500	2500	5000
WEIGHT (Kg)	80	135	172
OIL FLOW (l/min)	20-40	30-60	45-80
WORKING PRESSURE (bar)	160	180	200
ENGINE DISPLACEMENT (cc)	125	200	250
HEXAGON	50	50/70	50/70

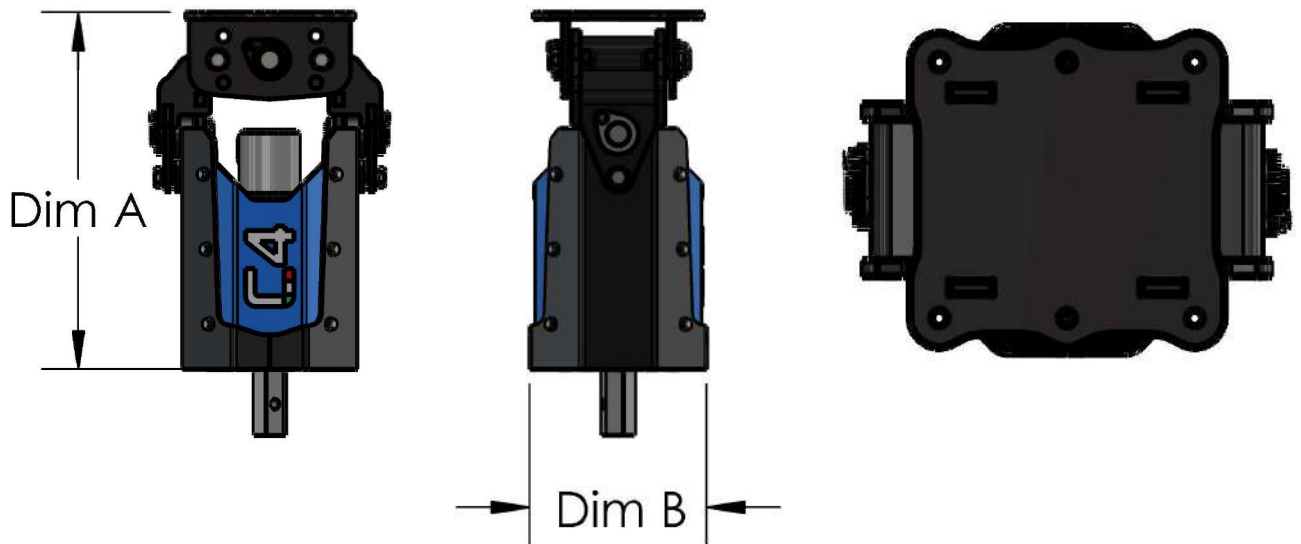

T/TV SERIES

Traction with reduced motor, inside the frame, protected from impacts or strokes.



T SERIES

Upper attachment characterized by double joint mounted on self-lubricating bushings, with possibility to block the rotations by screws.



T SERIES

Available as **optional**: standard attachment and pins with customized measurements and skid-steer adapter.



T/TV SERIES

Standard with 1.6mt hydraulic hoses.